

High Voltage Thick Film Chip Resistor



Scope

- This specification applies to all sizes of rectangular-type fixed chip resistors with Ruthenium-base as material.

Features

- Highly reliable multilayer electrode construction
- Higher component and equipment reliability
- Excellent performance at high voltage
- Reduced size of final equipment

Construction

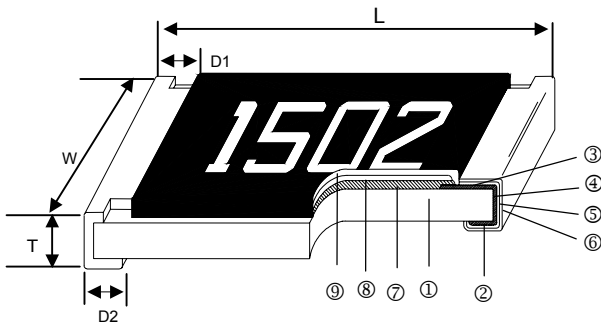

Applications

- Inverter
- Outdoor Equipments
- Converter
- Automotive Industry
- High Pulse Equipment

① Alumina Substrate	④ Edge Electrode (NiCr)	⑦ Resistor Layer (RuO ₂ /Ag)
② Bottom Electrode (Ag)	⑤ Barrier Layer (Ni)	⑧ Primary Overcoat (Glass)
③ Top Electrode (Ag-Pd)	⑥ External Electrode (Sn)	⑨ Secondary Overcoat (Epoxy)

Dimensions

Type	Size (Inch)	L (mm)	W (mm)	T (mm)	D1 (mm)	D2 (mm)	Weight (g) (1000pcs)
HVR02	0402	1.00±0.05	0.50±0.05	0.35±0.05	0.20±0.10	0.20±0.10	0.620
HVR03	0603	1.60±0.10	0.80±0.10	0.45±0.10	0.30±0.20	0.30±0.20	2.042
HVR05	0805	2.00±0.10	1.25±0.10	0.50±0.10	0.35±0.20	0.40±0.20	4.368
HVR06	1206	3.10±0.10	1.55±0.10	0.55±0.10	0.50±0.25	0.50±0.20	8.947
HVR0A	2010	5.00±0.10	2.50±0.15	0.55±0.10	0.60±0.25	0.50±0.20	24.241
HVR12	2512	6.35±0.10	3.10±0.15	0.55±0.10	0.60±0.25	0.50±0.20	39.448

Part Numbering

HVR	03	F	T	E	X	1001
Product Type	Dimensions	Resistance Tolerance	Packaging Code	TCR (PPM/°C)	Power Rating	Resistance
	02: 0402 03: 0603 05: 0805 06: 1206 0A: 2010 12: 2512	F: ±1% J: ±5%	T: Taping Reel B: Bulk	E: ±100 F: ±200 H: ±400	Y: 1/16W X: 1/10W W: 1/8W V: 1/4W U: 1/2W T: 1W	1001: 1KΩ 1004: 1MΩ 1005: 10MΩ

Recommend Land Pattern

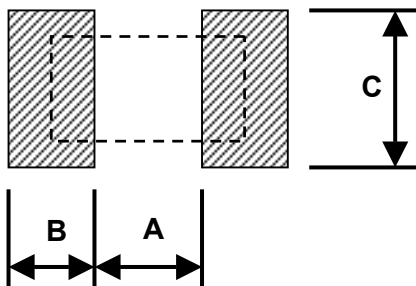

Type	A (mm)	B (mm)	C (mm)
HVR02	0.50	0.45	0.60
HVR03	0.90	0.60	0.90
HVR05	1.20	0.70	1.30
HVR06	2.00	0.90	1.60
HVR0A	3.80	0.90	2.80
HVR12	3.80	1.60	3.50
HVR02	0.50	0.45	0.60

Derating Curve

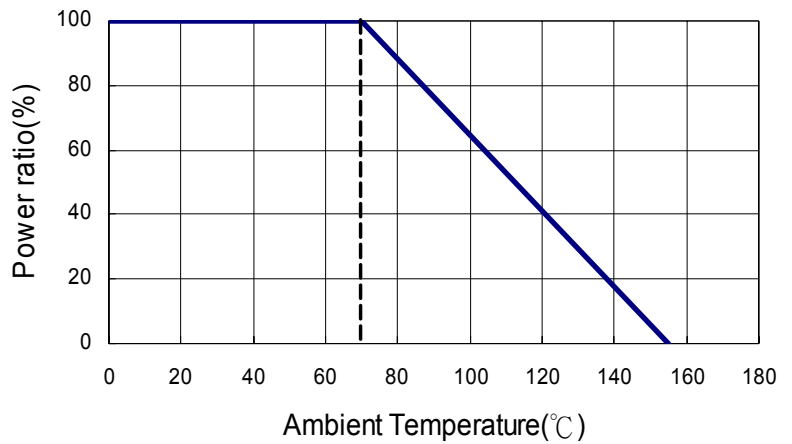

Soldering Condition

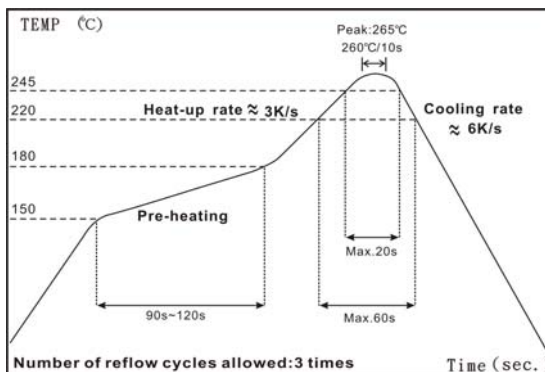

IR Reflow Soldering

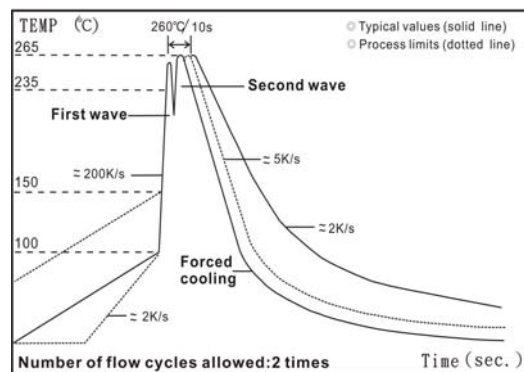

Wave Soldering (Flow Soldering)

- (1) Time of IR reflow soldering at maximum temperature point 260°C : 10s
- (2) Time of wave soldering at maximum temperature point 260°C : 10s
- (3) Time of soldering iron at maximum temperature point 410°C : 5s

Standard Electrical Specifications

Type	Item	Power Rating at 70°C	Operating Temp. Range	Max. Operating Voltage	Max. Overload Voltage	Resistance Range		TCR (PPM/°C)	
						±1%	±5%		
HVR02 (0402)	1/16W		-55 ~ +155°C	100V	200V	10Ω - 1MΩ		±100	
						1.02MΩ - 10MΩ	1.1MΩ - 20MΩ	±200	
						-	22MΩ - 100MΩ	±400	
HVR03 (0603)	1/10W				200V	400V	10Ω - 1MΩ		±100
							1.02MΩ - 10MΩ	1.1MΩ - 20MΩ	±200
							-	22MΩ - 100MΩ	±400
HVR05 (0805)	1/8W				400V	800V	10Ω - 1MΩ		±100
							1.02MΩ - 10MΩ	1.1MΩ - 20MΩ	±200
							-	22MΩ - 100MΩ	±400
HVR06 (1206)	1/4W				500V	1000V	10Ω - 1MΩ		±100
							1.02MΩ - 10MΩ	1.1MΩ - 20MΩ	±200
							-	22MΩ - 100MΩ	±400
HVR0A (2010)	1/2W			2000V	3000V	10Ω - 1MΩ		±100	
						1.02MΩ - 20MΩ	1.1MΩ - 20MΩ	±200	
						-	22MΩ - 100MΩ	±400	
HVR12 (2512)	1W			3000V	4000V	10Ω - 1MΩ		±100	
						1.02MΩ - 20MΩ	1.1MΩ - 20MΩ	±200	
						-	22MΩ - 100MΩ	±400	

Operating Voltage= $\sqrt{P \cdot R}$ or Max. operating voltage listed above, whichever is lower.

Overload Voltage= $2.5 \cdot \sqrt{P \cdot R}$ or Max. overload voltage listed above, whichever is lower.

■ Viking is capable of manufacturing the optional spec based on customer's requirement.

■ Environmental Characteristics

Item	Requirement		Test Method
	±1%	±5%	
Temperature Coefficient of Resistance (T.C.R.)	As Spec.		JIS-C-5201-1 4.8 IEC-60115-1 4.8 -55°C~+125°C, 25°C is the reference temperature
Short Time Overload	±(1.0%+0.05Ω)	±(2.0%+0.05Ω)	JIS-C-5201-1 4.13 IEC-60115-1 4.13 RCWV*2.5 or Max. Overload Voltage whichever is lower for 5 seconds
Insulation Resistance	≥10G		JIS-C-5201-1 4.6 IEC-60115-1 4.6 Max. Overload voltage for 1 minute
Endurance	±(2.0%+0.10Ω)	±(3.0%+0.10Ω)	JIS-C-5201-1 4.25 IEC-60115-1 4.25.1 70±2°C, RCWV for 1000 hrs with 1.5 hrs "ON" and 0.5 hrs "OFF"
Damp Heat with Load	±(2.0%+0.10Ω)	±(3.0%+0.10Ω)	JIS-C-5201-1 4.24 40±2°C, 90~95% R.H., RCWV for 1000 hrs with 1.5 hrs "ON" and 0.5 hrs "OFF"
Dry Heat	±(1.0%+0.05Ω)	±(1.5%+0.10Ω)	JIS-C-5201-1 4.23 IEC-60115-1 2.23.2 at +155°C for 1000 hrs
Bending Strength	±(1.0%+0.05Ω)	±(1.0%+0.05Ω)	JIS-C-5201-1 4.33 IEC-60115-1 4.33 Bending once for 5 seconds 2010, 2512 sizes: 2mm Other sizes: 3mm
Solderability	95% min. coverage		JIS-C-5201-1 4.17 IEC-60115-1 4.17 245±5°C for 3 seconds
Resistance to Soldering Heat	±(0.5%+0.05Ω)	±(1.0%+0.05Ω)	JIS-C-5201-1 4.18 IEC-60115-1 4.18 260±5°C for 10 seconds
Voltage Proof	No breakdown or flashover		JIS-C-5201-1 4.7 IEC-60115-1 4.7 1.42 times Max. Operating Voltage for 1 minute
Leaching	Individual leaching area ≤ 5% Total leaching area ≤ 10%		JIS-C-5201-1 4.18 IEC-60068-2-58 8.2.1 260±5°C for 30 seconds
Rapid Change of Temperature	±(0.5%+0.05Ω)	±(1.0%+0.05Ω)	JIS-C-5201-1 4.18 IEC-60115-1 4.18 -55°C to +155°C, 5 cycles

RCWV(Rated continuous working voltage)=√(P*R) or Max. Operating voltage whichever is lower.

■ Storage Temperature: 25±3°C; Humidity < 80%RH

■ Packaging

Reel Specifications & Packaging Quantity

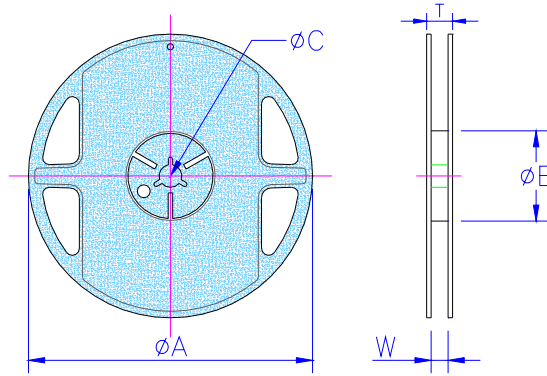

Type	Packaging Quantity	Tape Width	Reel Diameter	ΦA (mm)	ΦB (mm)	ΦC (mm)	W (mm)	T (mm)	
HVR02	Paper	10K	8mm	7 inch	178.5±1.5	60 ^{+1/-0}	13.0±0.2	9.0±0.5	12.5±0.5
		20K	8mm	10 inch	254±1.0	100±0.5	13.0±0.2	9.5±0.5	13.5±0.5
		40K	8mm	13 inch	330±1.0	100±0.5	13.0±0.2	9.5±0.5	13.5±0.5
HVR03 HVR05 HVR06	Paper	5K	8mm	7 inch	178.5±1.5	60 ^{+1/-0}	13.0±0.2	9.0±0.5	12.5±0.5
		10K	8mm	10 inch	254±1.0	100±0.5	13.0±0.2	9.5±0.5	13.5±0.5
		20K	8mm	13 inch	330±1.0	100±0.5	13.0±0.2	9.5±0.5	13.5±0.5
HVR0A HVR12	Embossed	4K	12mm	7 inch	178.5±1.5	60 ^{+1/-0}	13.0±0.5	13.0±0.5	15.5±0.5
		8K	12mm	10 inch	250±1.0	62±0.5	13.0±0.5	12.5±0.5	16.5±0.5

Paper Tape Specifications

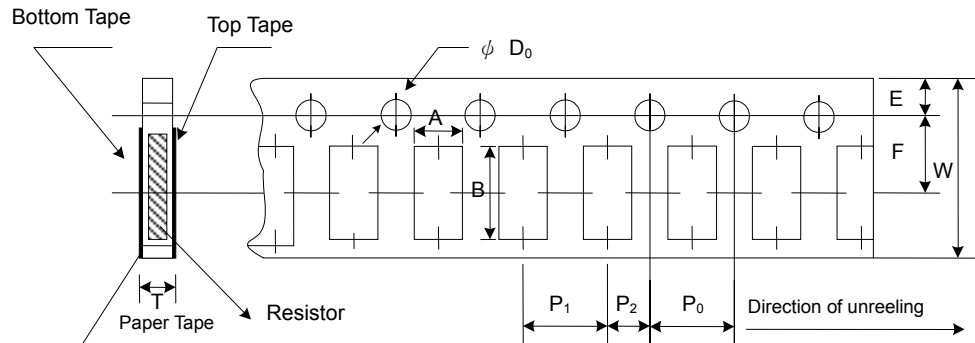

Type	A (mm)	B (mm)	W (mm)	E (mm)	F (mm)	P ₀ (mm)	P ₁ (mm)	P ₂ (mm)	ΦD ₀ (mm)	T (mm)
HVR02	0.65±0.10	1.15±0.10	8.0±0.20	1.75±0.10	3.50±0.05	4.00±0.10	2.00±0.05	2.00±0.05	1.50+0.1,-0	0.45±0.10
HVR03	1.10±0.10	1.90±0.10	8.0±0.20	1.75±0.10	3.50±0.05	4.00±0.10	4.00±0.05	2.00±0.05	1.50+0.1,-0	0.70±0.10
HVR05	1.60±0.10	2.40±0.20	8.0±0.20	1.75±0.10	3.50±0.05	4.00±0.10	4.00±0.05	2.00±0.05	1.50+0.1,-0	0.85±0.10
HVR06	1.90±0.10	3.50±0.20	8.0±0.20	1.75±0.10	3.50±0.05	4.00±0.10	4.00±0.05	2.00±0.05	1.50+0.1,-0	0.85±0.10

Embossed Plastic Tape Specifications

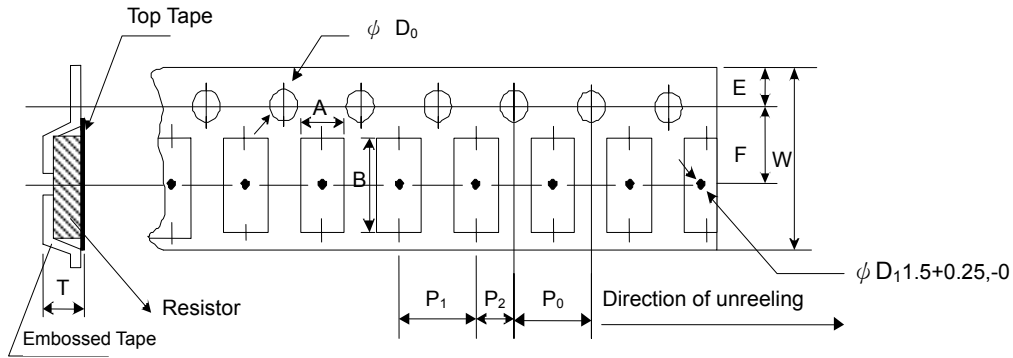

Type	A (mm)	B (mm)	W (mm)	E (mm)	F (mm)	P ₀ (mm)	P ₁ (mm)	P ₂ (mm)	ΦD ₀ (mm)	T (mm)
HVR0A	2.8±0.10	5.5±0.10	12.0±0.30	1.75±0.10	5.5±0.05	4.00±0.10	4.00±0.10	2.00±0.05	1.50+0.1, -0	1.2 ⁺⁰
HVR12	3.5±0.10	6.7±0.10	12.0±0.30	1.75±0.10	5.5±0.05	4.00±0.10	4.00±0.10	2.00±0.05	1.50+0.1, -0	1.2 ⁺⁰

■ Marking

No Marking for 0402

1% for 0805/1206/2010/2512: 4 digits marking

Example:

Resistance	100Ω	2.2KΩ	10KΩ	49.9KΩ	100KΩ
Marking	1000	2201	1002	4992	1003

5% for 0603/0805/1206/2010/2512: 3 digits marking in E24

Example: 101=100Ω 102=1KΩ (1st and 2nd are E24 code and 3rd code is multiplier)

E24 code	10	11	12	13	15	16	18	20	22	24	27	30	33	36	39	43	47	51	56	62	68	75	82	91
----------	----	----	----	----	----	----	----	----	----	----	----	----	----	----	----	----	----	----	----	----	----	----	----	----

1% for 0603: 3 digits marking in E96

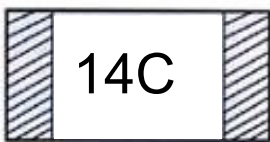

3 digits marking for Example: 14C=13K7Ω 13C=13K3Ω
68B=4K99Ω 68X=49.9Ω

■ Marking Table

Code	E96	Code	E96	Code	E96	Code	E96			
01	100	25	178	49	316	73	562			
02	102	26	182	50	324	74	576			
03	105	27	187	51	332	75	590			
04	107	28	191	52	340	76	604			
05	110	29	196	53	348	77	619			
06	113	30	200	54	357	78	634			
07	115	31	205	55	365	79	649			
08	118	32	210	56	374	80	665			
09	121	33	215	57	383	81	681			
10	124	34	221	58	392	82	698			
11	127	35	226	59	402	83	715			
12	130	36	232	60	412	84	732			
13	133	37	237	61	422	85	750			
14	137	38	243	62	432	86	768			
15	140	39	249	63	442	87	787			
16	143	40	255	64	453	88	806			
17	147	41	261	65	464	89	825			
18	150	42	267	66	475	90	845			
19	154	43	274	67	487	91	866			
20	158	44	280	68	499	92	887			
21	162	45	287	69	511	93	909			
22	165	46	294	70	523	94	931			
23	169	47	301	71	536	95	953			
24	174	48	309	72	549	96	976			
Code	A	B	C	D	E	F	X	Y		
Multiplier	10 ⁰	10 ¹	10 ²	10 ³	10 ⁴	10 ⁵	10 ⁻¹	10 ⁻²		